

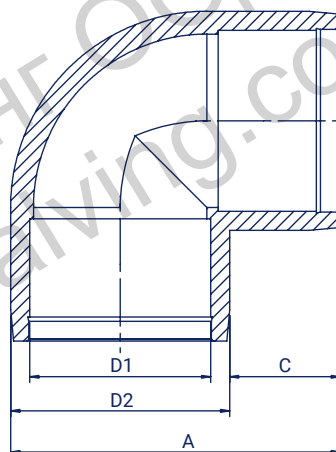

ELECTROFUSION ELBOW 90° SDR 11

Kolano elektrooporowe 90° SDR 11
Отвод Электросварной 90° SDR 11

- **application: water and gas** | zastosowanie: woda i gaz | применение: вода и газ
- **16 bar water, 10 bar gas** | 16 bar woda, 10 bar gaz | 16 бар - вода, 10 бар - газ
- **MRS - 10 MPa** | Минимальное сопротивление - 10 МПа
- **centre stop** | ogranicznik | ограничитель



Size Wymiar Размер D1 (mm)	Code Kod Код	A (mm)	D2 (mm)	C (mm)	Weight Waga Вес (kg)	Raw material Tworzywo Материал	Packing Pakowanie Упаковка
20	KE9002011	77	35	43	0,08	PE 100-RC	150
25	KE9002511	77	35	43	0,07	PE 100-RC	150
32	KE9003211	82	42,5	40	0,07	PE 100-RC	120
40	KE9004011	94	52	46	0,29	PE 100-RC	60
50	KE9005011	105	60	45	0,23	PE 100-RC	40
63	KE9006311	125	80	46	0,29	PE 100-RC	25
75	KE9007511	157	95	64	0,52	PE 100-RC	15
90	KE9009011	175	112	65	0,79	PE 100-RC	10
110	KE9011011	198	135	65	1,13	PE 100-RC	8
125	KE9012511	224	149	75	1,51	PE 100-RC	10
160	KE9016011	275	193	81	3,00	PE 100-RC	4
180	KE9018011	320	220	100	5,30	PE 100-RC	1
200	KE9020011	375	245	130	7,40	PE 100-RC	1
225	KE9022511	410	270	140	11,30	PE 100-RC	1